

TOP VIEW

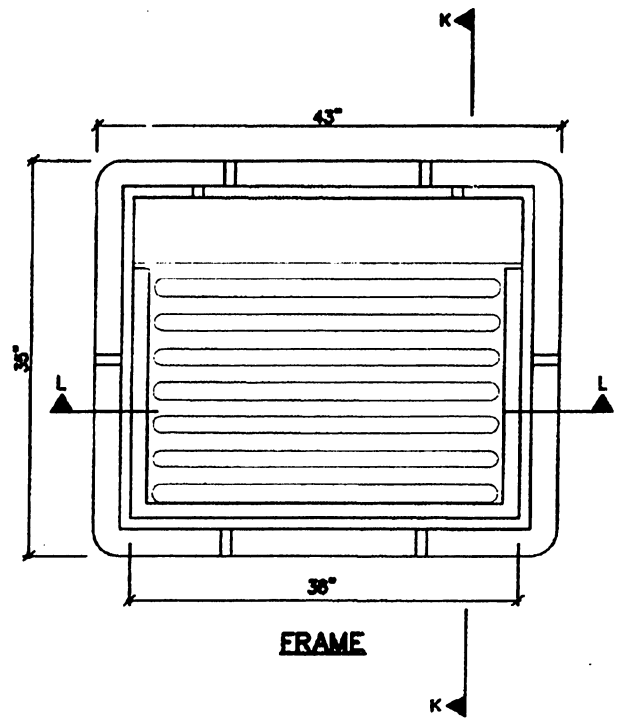

FRAME

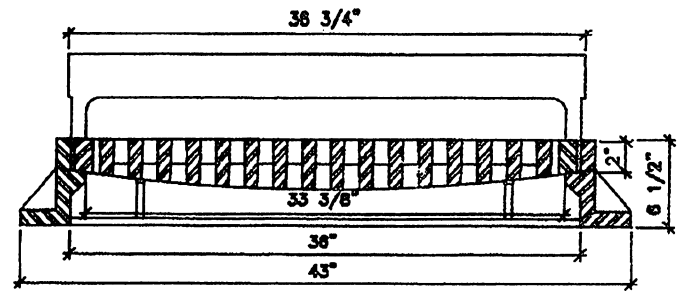

SECTION I-I

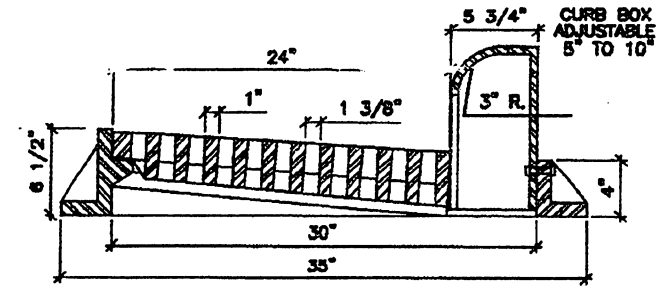

SECTION K-K

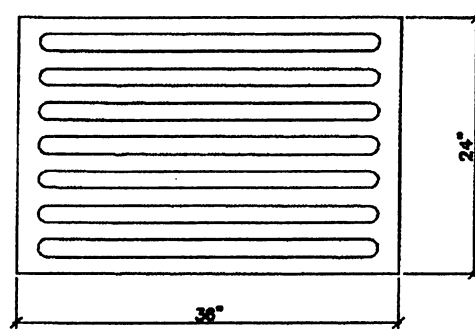

ALTERNATE GRATE

LEGEND:
e = % SUPERELEVATION

NOTES:

- 1- PORTLAND CEMENT CONCRETE SHALL BE CLASS A.
- 2- USE THE BICYCLE GRATE EXCEPT WHEN OTHERWISE INDICATE ON THE PLANS
- 3- THE CONTRACTOR IS RESPONSIBLE TO TRANSITION ADJACENT CURBS, CURBS AND GUTTERS AND CONCRETE BARRIERS TO COMFORM WITH THE SHAPE OF THE METAL CURB AS A SUBSIDIARY OBLIGATION.
- 4- REINFORCING STEEL SHALL BE GRADE 60, AASHTO M-31 OR M-31M.
- 5- NO ALUMINUM STEPS WILL BE REQUIRED WHERE DEPTH IS 1.00 OR LESS. INSTALL ONE STEP .40 ABOVE FLOOR WHEN DEPTH IS MORE THAN 1.00 BUT LESS THAN 1.50. WHERE DEPTH IS MORE THAN 1.50, STEPS SHALL BE EVENLY SPACED AT .30 INTERVALS FROM .40 ABOVE FLOOR TO WITHIN .60 OF THE TOP OF THE BOX. PLACE STEPS IN WALL WITHOUT PIPE AND ADJACENT TO FRAME OPENING.
- 6- ALL GRAY CAST IRON PRODUCTS USED IN THE "DR" SERIES OF THE STANDARD DRAWINGS MUST BE FROM APPROVED MANUFACTURERS AND THE APPROVED PRODUCTS IDENTIFIED BY PRODUCT NUMBER OR CATALOG NUMBER LISTED IN THE APPROVED LIST OF MANUFACTURERS AND PRODUCTS CONTAINED IN THE FIRST PAGE OF THE "DR" SERIES.

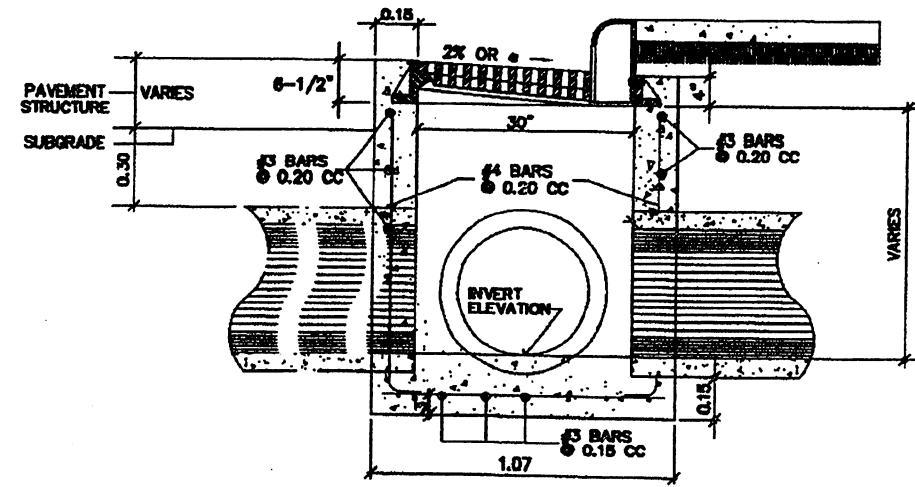

SECTION J-J

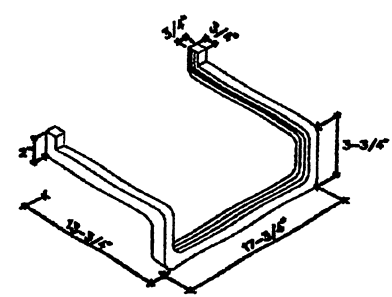

ALUMINUM STEP DETAIL

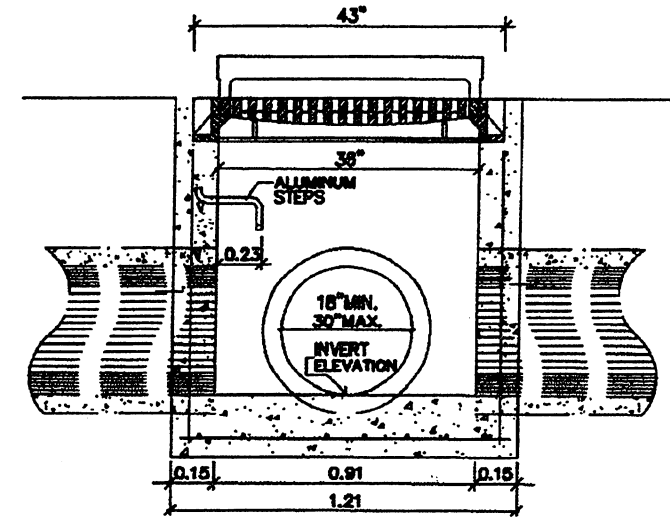

SECTION I-I

EFFECTIVE DATE: DECEMBER 1998

COMMONWEALTH OF PUERTO RICO
DEPARTMENT OF TRANSPORTATION
AND PUBLIC WORKS
HIGHWAY AND TRANSPORTATION AUTHORITY

**DRAINAGE
INLET TYPE 1**
FROM 18" MIN. TO 30" MAX.
ALTERNATE GRATE

DATE	REVISION	BY	
12-1998	DELETE NOTES, ADD NOTE 8	LV.	

RECOMMENDED BY: <i>[Signature]</i> DESIGN AREA DIRECTOR DATE: 12-7-98	APPROVED BY: <i>[Signature]</i> EXECUTIVE DIRECTOR DATE: 8-21-98
APPROVED BY: <i>[Signature]</i> DIV. ADM. FHWA-PR DIVISION DATE: 12-7-98	

STD. DWG.	DR 7 OF 40
-----------	------------