

TYPE 1 MANHOLE RISER SYSTEM

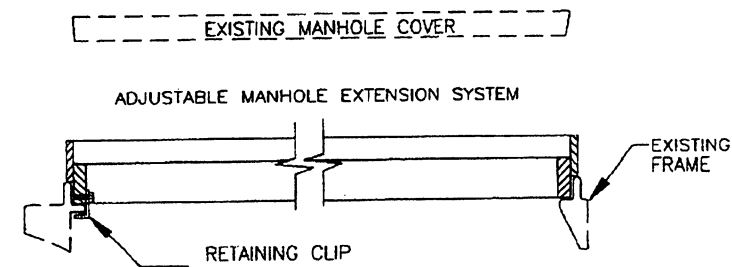

TYPICAL INSTALLATION AND
RETAINING CLIP DETAIL

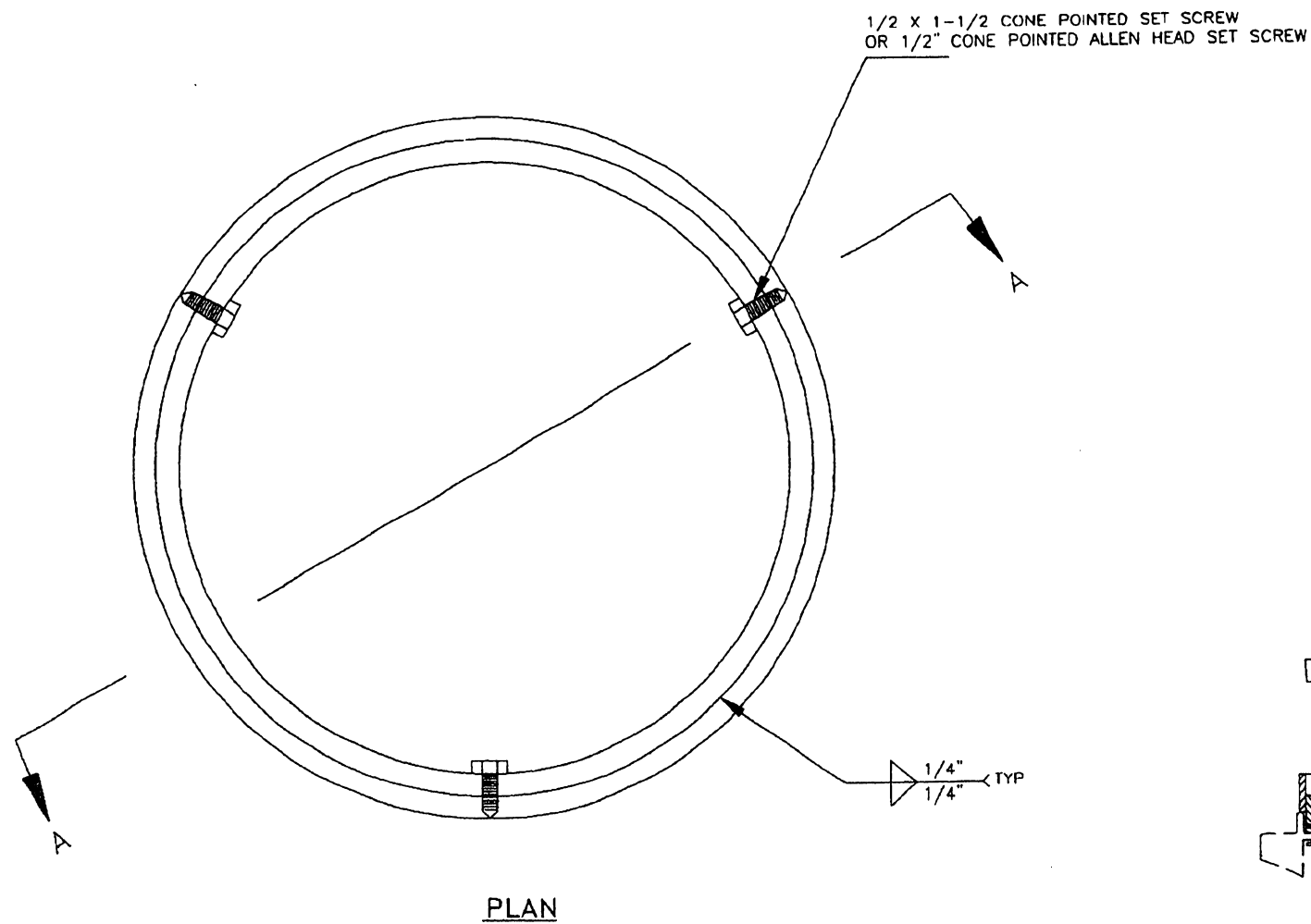
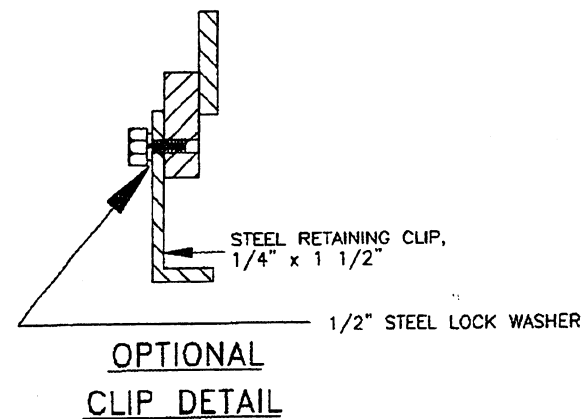
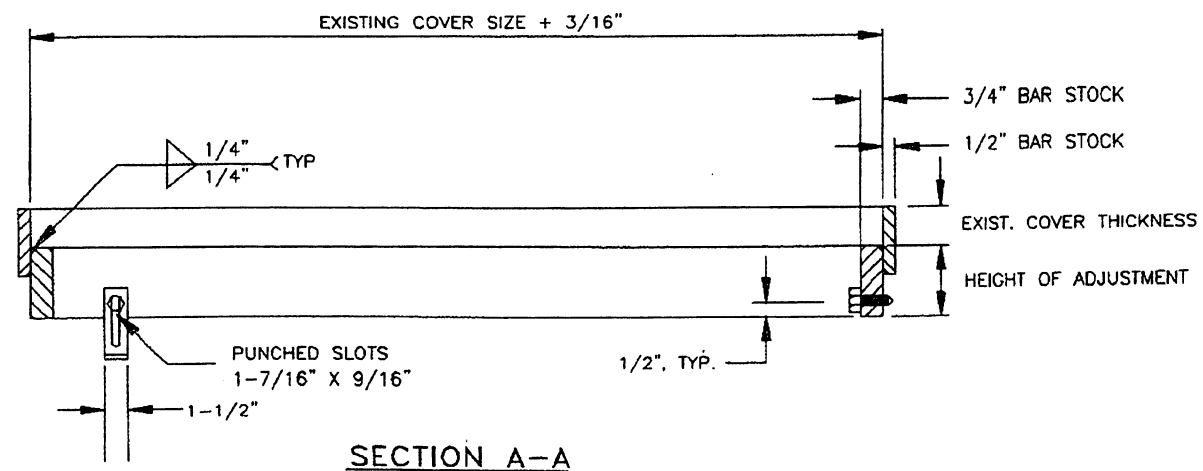

NOTES

- ALL COMPONENTS ARE MANUFACTURED FROM U.S. MADE CARBON STEEL MEETING OR EXCEEDING THE MINIMUM REQUIREMENTS OF A.S.T.M. A-36.
- TOP AND BOTTOM RINGS ARE WELDED CONTINUOUSLY.
- THIS SYSTEM IS USED WHEN THE RISE IS THICKER THAN THE LID.
- MINIMUM HEIGHT OF ADJUSTMENT IS MANHOLE LID THICKNESS + 1/4".
- EACH ADJUSTMENT RING IS CUSTOM FABRICATED FROM MEASUREMENTS PROVIDED WITH EACH ORDER. REQUIRED MEASUREMENTS INCLUDE:
 - EXIST. MANHOLE COVER DIAMETER AND THICKNESS
 - REQUIRED HEIGHT OF ADJUSTMENT FROM TOP OF EXISTING LID TO FINISHED ELEVATION. MAXIMUM RECOMMENDED HEIGHT OF ADJUSTMENT FOR REPAVING PROJECTS IS 6". HEIGHT ADJUSTMENTS ARE AVAILABLE IN 1/4" INCREMENTS.
 - REQUIRED LENGTH AND TYPE OF RETAINER CLIP.
 - WIDTH AND HEIGHT OF EXISTING CASTING BEARING SURFACE.
- DURING INSTALLATION CHECK FOR FULL BEARING OF LOWER FRAME SECTION ON EXISTING CASTING.
- RISERS SHALL BE COATED WITH BLACK ASPHALT BITUMINOUS PAINT
- IN LIEU OF CONE TIPPED BOLTS FOR ATTACHMENT TO FRAME INCLUDE DRILLED AND TAPPED BAR STOCK WITH 1/2" DIA. -1" LONG STEEL BOLT, LOCK WASHER AND CLIPS..
- IT SHALL BE A SUBSIDIARY OBLIGATION OF THE CONTRACTOR TO TAKE ALL NECESSARY MEASUREMENT OF THE EXISTING MANHOLE COVER AND FRAME THAT WILL ALLOW THE APPROPRIATE FABRICATION OF THE ADJUSTMENT RING. THE EXCAVATION AND REPLACEMENT OF THE EXISTING PAVEMENT STRUCTURE SHALL BE A SUBSIDIARY OBLIGATION OF THE CONTRACT.
- UNLESS OTHERWISE INDICATED IN THE CONTRACT, THE CONTRACTOR MAY USE TYPE 1, 2, 5, OR 7 AT HIS CHOICE.
- THE USAGE OF EACH TYPE OF ATTACHMENT WILL BE LEFT AT THE SELECTION OF THE CONTRACTOR

EFFECTIVE DATE: OCTOBER 2000

COMMONWEALTH OF PUERTO RICO DEPARTMENT OF TRANSPORTATION AND PUBLIC WORKS HIGHWAY AND TRANSPORTATION AUTHORITY		
DRAINAGE MANHOLE ADJUSTMENT		RECOMMENDED BY: <i>[Signature]</i> DESIGN AREA DIRECTOR DATE: 12/20/00
MANUFACTURED BY ANDREWS METAL PRODUCTS 745 ANDREWS AVE YOUNGSTOWN, OHIO 44505 PH 1-800-837-3901 FAX 330-744-1044 EMAIL: SALES@ANDREWSMETALPRODUCTS.COM		APPROVED BY: <i>[Signature]</i> EXECUTIVE DIRECTOR DATE: 12-20-00
DATE	REVISION	BY
STG. DWG. 25A OF 40		DR