

TOP VIEW MOUNTING RING
SCALE: N.T.S.

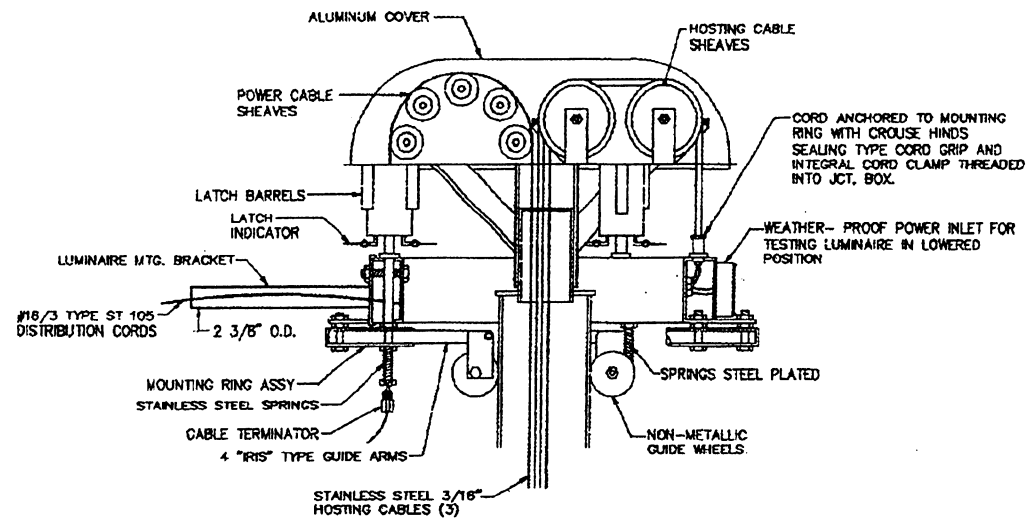

HEAD FRAME AND MOUNTING RING ASSEMBLY
SCALE: N.T.S.

NOTE:

1. A No.8 AWG CU BARE STRANDED GROUND CONDUCTOR SHALL BE RUN FROM THE SERVICE CONNECTING ALL POLES. THE GROUND CONDUCTOR IS TO BE 0.08m DIRECTLY ABOVE THE CONDUIT.

EFFECTIVE DATE: JUNE 1996

COMMONWEALTH OF PUERTO RICO
DEPARTMENT OF TRANSPORTATION
AND PUBLIC WORKS
HIGHWAY AND TRANSPORTATION AUTHORITY

HIGHMAST
DETAIL

RECOMMENDED BY: *[Signature]*
DESIGN AREA DIRECTOR
DATE: *Aug 20, 91*

APPROVED BY: *[Signature]*
EXECUTIVE DIRECTOR
DATE: *4/24/96*

APPROVED BY: *[Signature]*
DIV. ADM. FHWA-PR DIVISION
DATE:

DATE	REVISION	BY	STD. DWG.	LS
				15 OF 17