

**SECTION "D-D"**  
NOT TO SCALE

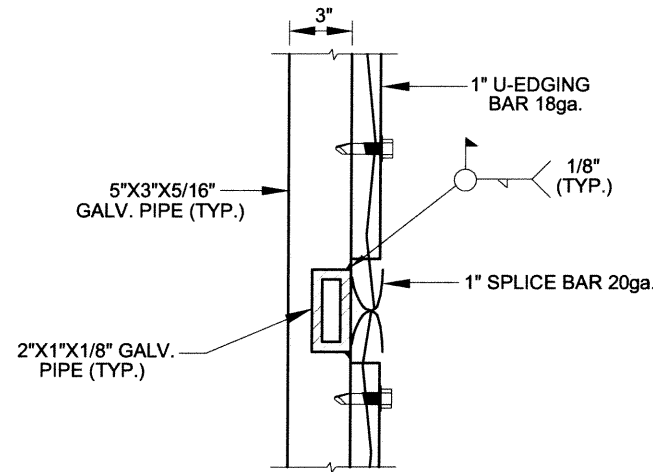

**SECTION "C-C"**  
NOT TO SCALE

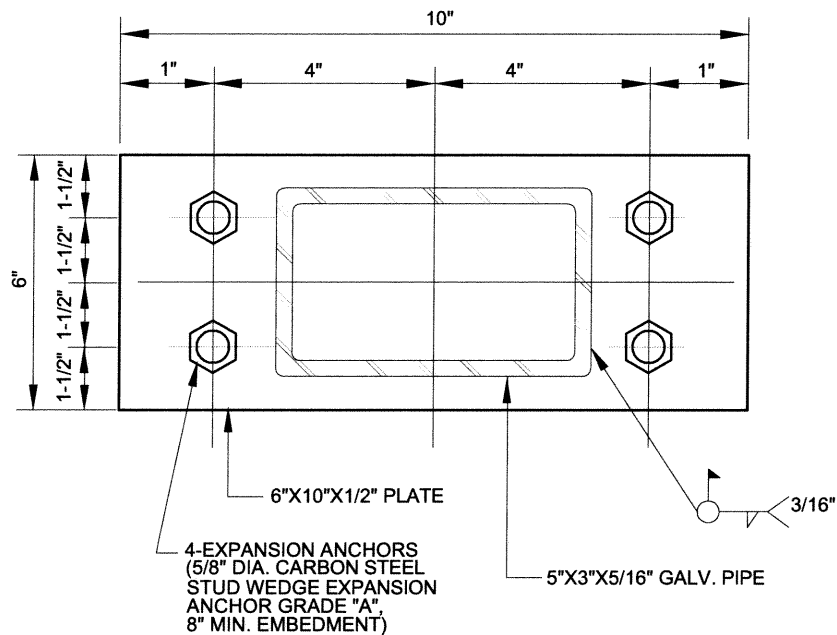

**SECTION "B-B"**  
NOT TO SCALE

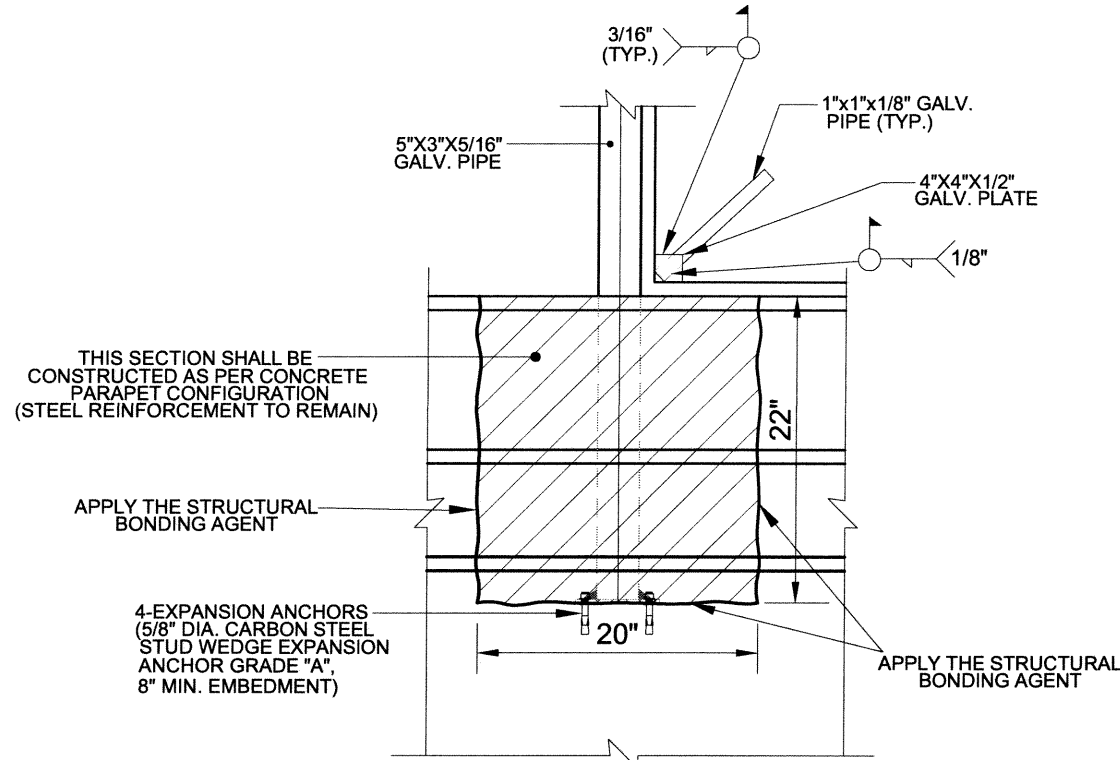

**DETAIL "D"**  
NOT TO SCALE

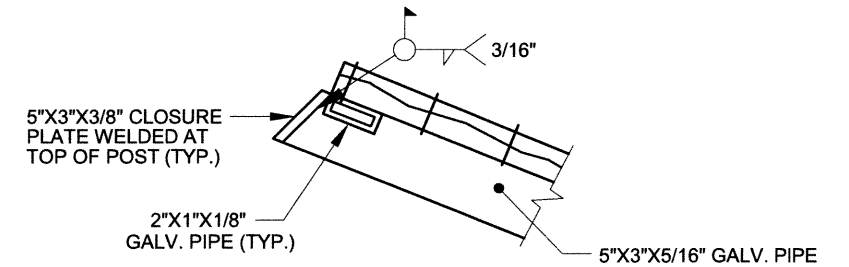

**DETAIL "C"**  
NOT TO SCALE

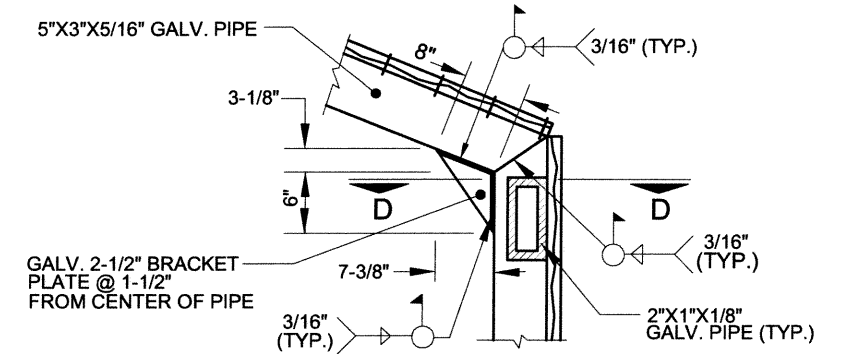

**DETAIL "B"**  
NOT TO SCALE

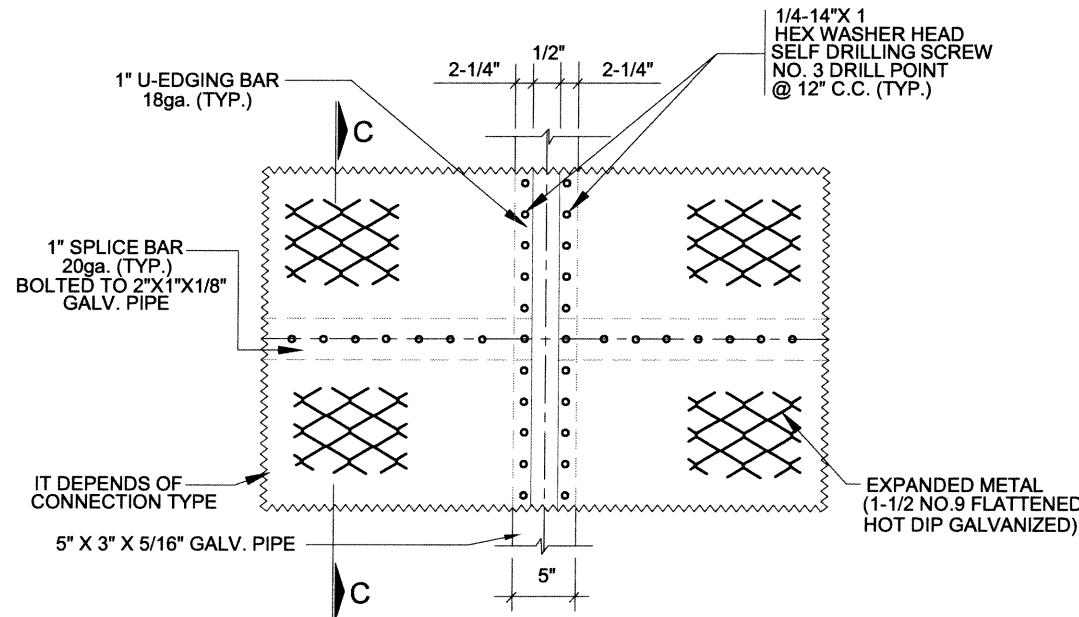

**TYPICAL DETAIL OF EXPANDED METAL POST CONNECTION**  
NOT TO SCALE

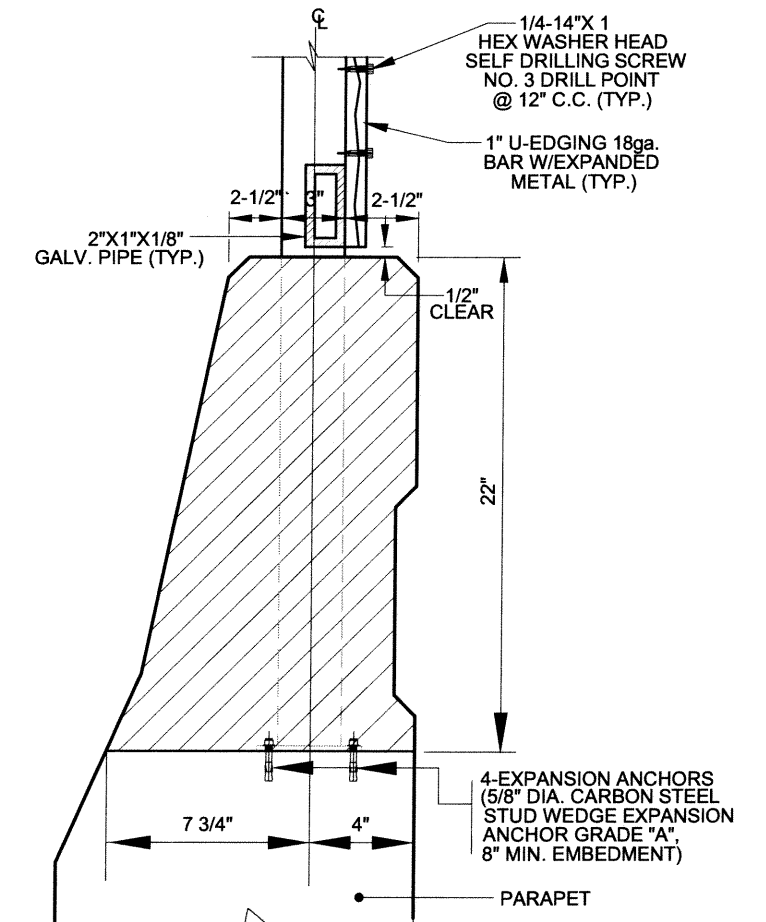

**DETAIL "A"**  
NOT TO SCALE

DATE	REVISION	BY	DATE	REVISION	BY



COMMONWEALTH OF PUERTO RICO  
DEPARTMENT OF TRANSPORTATION AND PUBLIC WORKS  
HIGHWAY AND TRANSPORTATION AUTHORITY

23/11/09  
DATE:

STANDARD DRAWING APPROVED BY:  
*[Signature]*  
DEPUTY EXECUTIVE DIRECTOR FOR INFRASTRUCTURE

MISCELLANEOUS BRIDGE DETAILS  
EXPANDED METAL FENCE FOR BRIDGE

MBD-3  
SEPTEMBER 2009